



Member Clean Energy Council of Australia

19.5M WINCH TOWER INSTALLATION MANUAL



CERTIFIED to
AS4100 Steel Structures Code
AS3995 (1994) Design of Steel Lattice
Towers and Masts
AS1170.2 (1989) SAA Wind Loading
Code

49 Vista Avenue North, Copacabana, NSW 2251
Ph (02) 43811531 Mobile 0407 669313
Fax (02) 43821880 Email: sunrise@comcen.com.au

1. COMPONENT CHECKLIST

The 19.5 metre tower kit from Sunrise Solar contains the following parts:

<u>DESCRIPTION</u>	<u>QTY</u>	<u>CHECKED</u>
22.1m of wire rope with one end crimped on thimble	4
17.8m of wire rope with one end crimped on thimble	4
13.2m of flex wire rope with one end crimped on thimble	4
20m of flex wire rope with one end crimped on thimble	1
Turnbuckles	13
Brake Winch	1
Small D Shackles	38
Large D Shackle for end of winch rope	1
Small wire rope grips	24
Large wire rope grips	12
Thimbles	12
20mm dia x 120mm stainless steel bolt & nut	2
16mm dia x 120mm stainless steel bolt & nut	6
16mm dia x 110mm stainless steel bolt & nut	2
12mm dia x 40mm galvanised bolt & nut with 2 washers	4
10mm dia x 25mm galvanised bolt & nut	3
10mm dia x 90mm galvanised bolt & nut	2
10mm dia x 120mm galvanised bolt & nut	1
Top guy sleeve	1
Middle guy sleeve	1
Bottom guy sleeve	1
Gin Pole joiner sleeve	1
Base plate for poles	1
12mm dia steel wire loops	4
Winch bracket	1
Steel plate with seven holes	1
Installation manual	1

Sunrise Solar have completed a checklist at the time of packing to minimise the chance of short supply. However, check that all parts are present before going to site if possible.

TOWER POLES

The poles are supplied seperately from the tower kit.

If you have ordered poles as well, you should have recieved three 80mm NB (nominal bore or inside diameter) 6.5m lengths of galvanised pipe. These are for the centre mast.

Also you should have recieved one 65mm NB medium wall 6.5m length of galvanised pipe and one 65mm NB medium wall 3.25m length of galvanised pipe. These are for the gin pole.

This is used for leverage to raise the centre mast.

The pipes will all be pre drilled and ready for installation.

A general idea of the location of these components is given in fig 1.

YOU SUPPLY : LOCTITE 243, CONCRETE AND REINFORCING FOR THE CONCRETE AND APPROX 8M OF FENCING WIRE FOR LOCKING THE TURNBUCKLES. You will also need 30m of 5mm rope temporarily to stabilise the gin pole during raising and lowering of the

tower.

For concrete reinforcing you will need 48 600mm lengths of 12mm deformed reinforcing bar (12 in each outside hole) and 10 900mm lengths of 12mm reinforcing bar for the centre hole. If you need to put foundations into rock then contact Sunrise Solar for advice on using chemical rock anchors.

When ordering concrete you will need at least 1.7m³. You may need a little extra depending on how neat you dig the holes. Also, if the soil is very sandy you may need larger holes.

The Loctite 243 is required for some of the bolts both on the tower and the wind generator.

If you are in a corrosive environment, you will need to cover the steel wire ropes and fittings with a wire rope grease to protect against rusting.

2. FOUNDATIONS

2.1 Layout

The concrete foundations for the tower should be laid at least 2 days prior to installing the tower. Holes for the foundations should be dug in accordance with fig. 2. The centre hole should be 1m x 1m x 0.25m deep. The 4 outside holes should each be 0.7m x 0.7m x 0.7m. If the soil is sandy, then go larger on the holes.

In laying out the foundations you must decide in which direction you wish to lower the mast then layout the holes accordingly.

Holes no. 2 & 4 should be slightly forward and below the centre hole if possible. This will ensure that the guys slacken as soon as the tower begins to lower. If holes 2 & 4 were to be a bit to the winch side of centre or a good deal higher than the centre hole then it is possible that the guys attached to these holes may tension and resist the tower from being lowered. This would not be catastrophic, but would necessitate the slackening of the turnbuckles on these wires before lowering the tower, which is inconvenient.

Holes 1, 3 & 5 should be in line with each other, but their relationship in the vertical direction is not terribly important, i.e. they don't have to lie in the same horizontal plane.

All guy ropes have 1.5 metres of extra length to allow for uneven ground situations.

2.2 Concreting

Once the holes are dug you should place the steel wire loops, winch bracket, base plate and reinforcing rod near their respective holes.

Place some flexible or corrugated conduit in the centre hole so that after the concrete has set, you have a means of neatly bringing your cable up from it's trench into the inside of the mast.

Pour the concrete and place the reinforcement rod in during pouring.

Immediately after pouring a hole, while the concrete is still wet, push in the steel base plate and winch bracket.

The steel loops should be angled towards the top of the pole.

The base plate should sit flush on top of the centre pad and the vertical fins should be in line with holes 1 & 3. The upper 22mm hole in the baseplate fins should be closest to the winch.

The winch bracket should be angled slightly backwards away from the tower with the channel side facing away from the tower. Leave 400mm of winch bracket protruding above the concrete.

Allow the concrete 2 days to set before connecting the poles to the base plate and raising the tower. After a few hours though, once the concrete has gone off, you can proceed to layout the poles in position and connect the guy wires to the outside steel loops if you wish.

3 ASSEMBLY AND RAISING THE TOWER

1. Take the 80mmNB pipe with the 22mm hole in one end and lay it out on the ground in the direction that it will lower to, with the 22mm hole at the centre bracket.
2. Use a 20mm dia. stainless steel bolt to bolt it to the lower hole in the centre plate. Use Loctite on the nut.
3. Feed the connecting cable up the conduit that you placed in the centre concrete pad and through this first length of pipe, pulling through an extra 13m of cable beyond the end of the pipe.
4. Feed one of the mast sleeves down over the cable onto the top of this pipe and bolt it on using a M16x120mm stainless steel bolt, making sure that the fins are in line with the outside foundations. Use Loctite on the nut.
5. Feed the excess cable through the second length of 80mm pipe.
6. Slide the second pipe into the sleeve and bolt it on, joining the first and second lengths of pipe. Use Loctite on the nut.
7. Repeat for the next sleeve and the third length of mast pipe, making sure that this top length of pipe has the 12mm dia. holes at the top of the tower.
8. Slide the top sleeve down over the top of the mast until it lines up with the lower 18mm holes in the mast, about 1.4m from the top. Bolt the sleeve on using the stainless steel bolts provided and Loctite on the nut. Use the spare 10mm dia x 120mm galvanised bolt and nut to bolt into the hole near the top of the mast. This can be used to anchor the electrical cable so that the wind generator connections are not bearing the weight of the cable inside the mast. Simply tie a loop in the cable around this bolt.
9. Lay the full length 65mm gin pole on top of the first 80mm pipe and bolt it to the upper hole in the base plate using the remaining 20mm stainless steel bolt and Loctite on the nut. Then add the 3.25m length of gin pole to the end of the 6.5m length using the gin pole joiner sleeve. The sleeve clamps around the two sections of gin pole and an M16x110mm stainless steel bolt must pass through the sleeve and gin pole at each end of the sleeve. Use Loctite on all nuts.
10. Bolt the steel plate inside the free end of the gin pole, with the three holes for the guy wires along the top edge.

11. Shackle the crimped end of the 22m upper guy wires to the top sleeve.
12. Shackle the crimped end of the 17m centre guy wires to the centre sleeve, then repeat for the 13m guys on the lower sleeve.
13. Measure off the top guys at 19.2m and feed each of them around a thimble using one of the large rope grips to secure temporarily. Repeat for the centre guys at 16.3m length and the bottom guys at 11.7m length, using the smaller rope grips.
14. Shackle each thimble to a turnbuckle and adjust each turnbuckle to the midway point.
15. Shackle the other end of each turnbuckle to the appropriate steel loop on the outside foundations. The ropes that connect to the ginpole attach to the steel plate attached to the end of the gin pole.
16. Connect the flexible 20m winch cable to the winch drum and using the large D shackle, attach the crimped end to the 25mm hole in the steel plate at the end of the gin pole. Also shackle the remaining turnbuckle onto the steel plate. This turnbuckle will be used for connecting the gin pole to the steel loop in the concrete next to the winch. Ensure this turnbuckle is in the midway position. Now tie a temporary rope from the end of the gin pole to each of the outside foundations numbered 2 & 4. This will help stabilise the gin pole during raising & lowering.
17. Bolt the winch to the winch bracket.
18. Winch the tower into the upright position checking that the guy ropes are not getting too tight on the way up. If any are, then loosen by releasing some rope through the rope grip. Shackle the turnbuckle on the end of the gin pole to the steel loop next to the winch bracket.
19. Check that the tower is straight and vertical and release each rope grip one at a time, taking up any slack in the ropes.
20. Attach the remaining rope grips making sure there are three on each guy, attaching the loose ends neatly up the guys. See fig 3.
21. Adjust the turnbuckles to put tension on each guy.
22. To lower the tower, unscrew the turnbuckle attaching the gin pole to the winch foundation. Lower using the winch, checking that the guy wires are getting looser. Raise and lower the tower a couple of times until you are happy that it is ready for the wind generator.
23. Lower the tower and gin pole to the ground and grease the wire ropes and fittings if necessary for your environment. Raise the gin pole again and allow the top of the mast to sit at comfortable working height above the ground, then attach the wind generator as per the manufacturer's instructions.
24. Raise the wind generator once wiring is completed to the battery.
25. Using fencing wire or something of similar strength, lock the turnbuckles in place so they cannot vibrate loose. Do this by passing a length of wire through one eye of the turnbuckle, through the body of the turnbuckle and then through the other eye, twisting the two loose ends together.

→

WARNING

If the turnbuckles are not locked in position they could vibrate loose resulting in the tower falling to the ground .

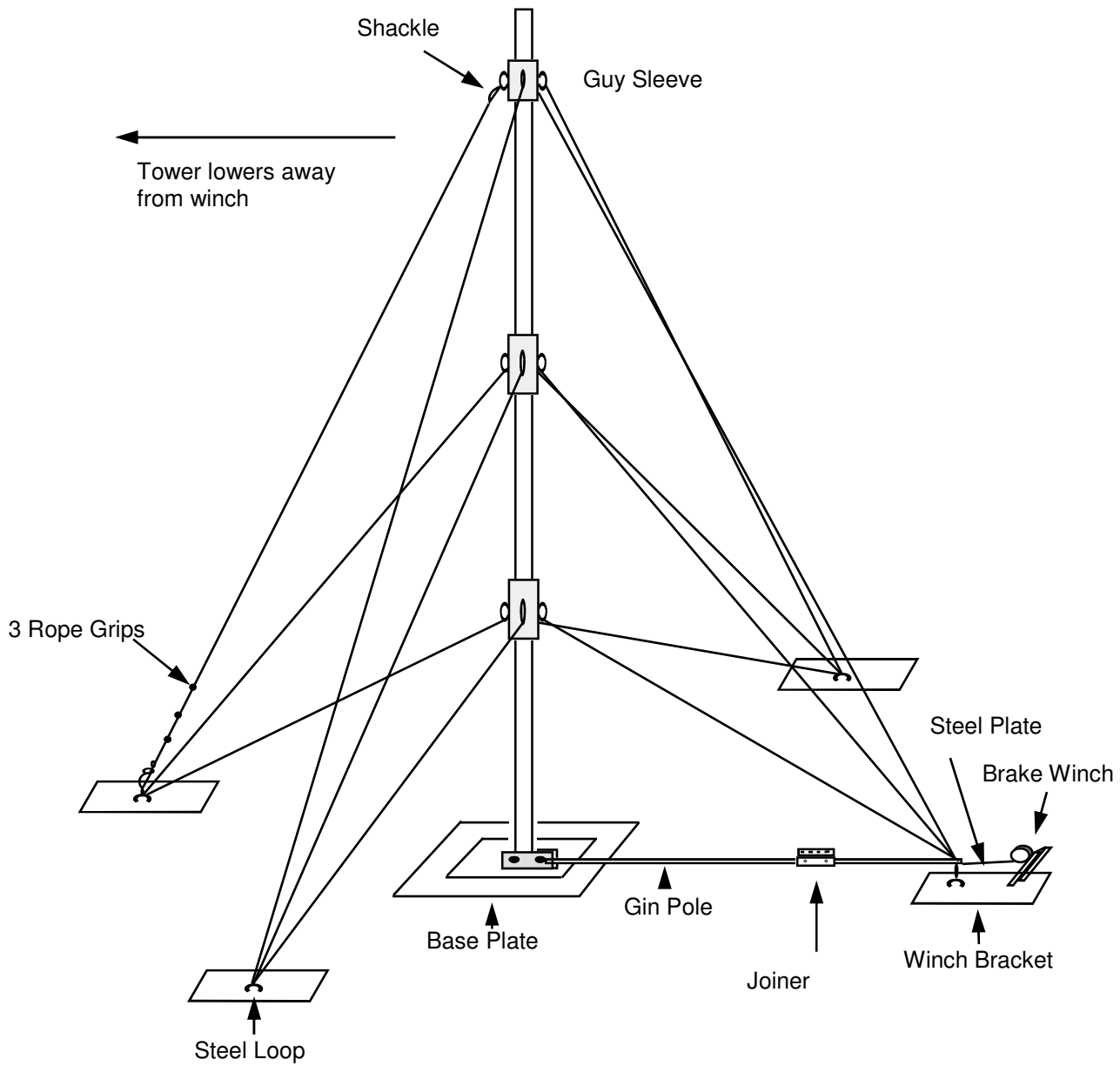

**Sunrise Solar 19.5m
Winch Tower**

Fig 1

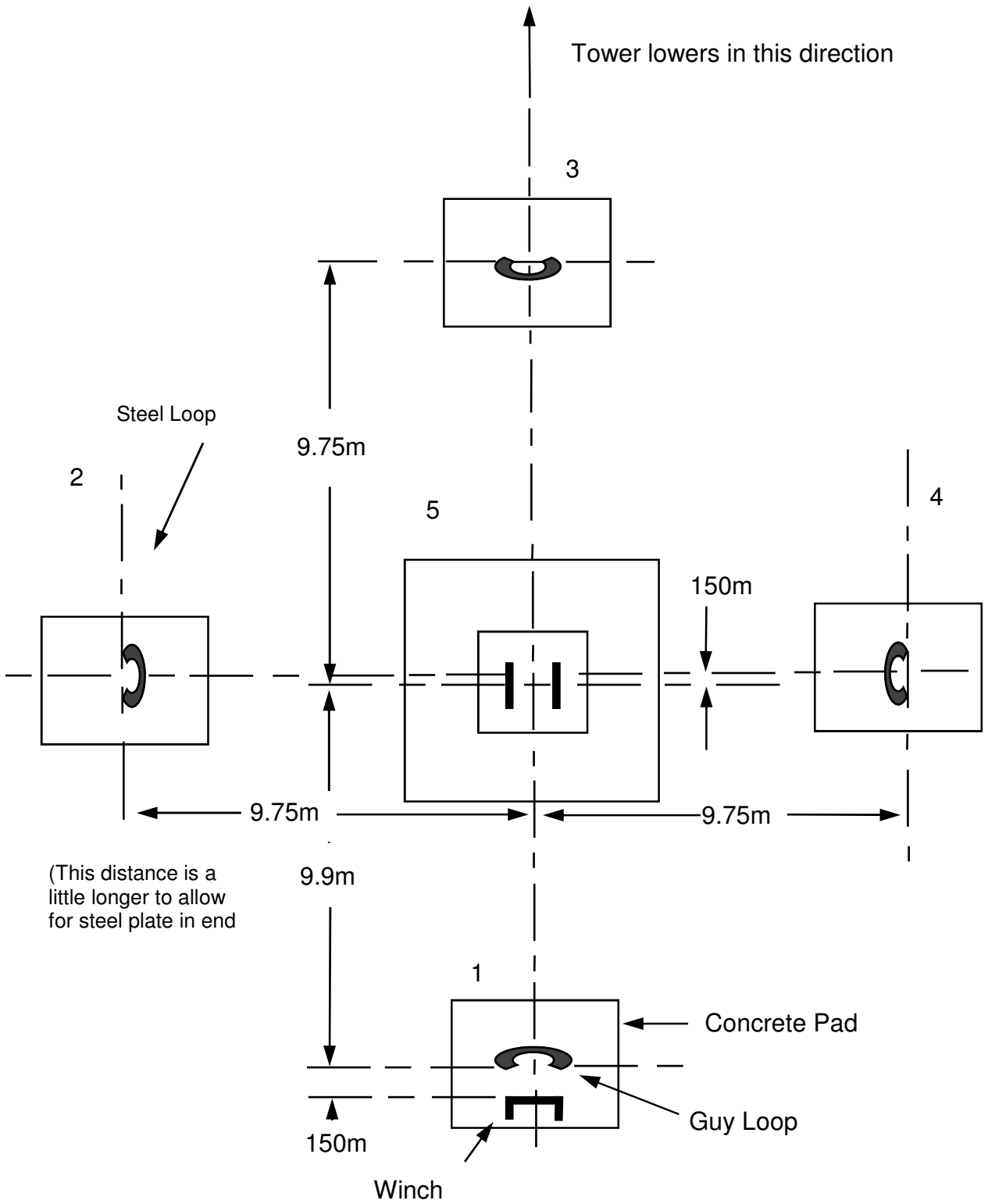

NOTE. Foundations 2 & 4 slightly forward of centre line by approximately 150mm.

Fig 2. Plan view of 19.5m Tower Foundations

Fig 3 Cross Section View of Foundations

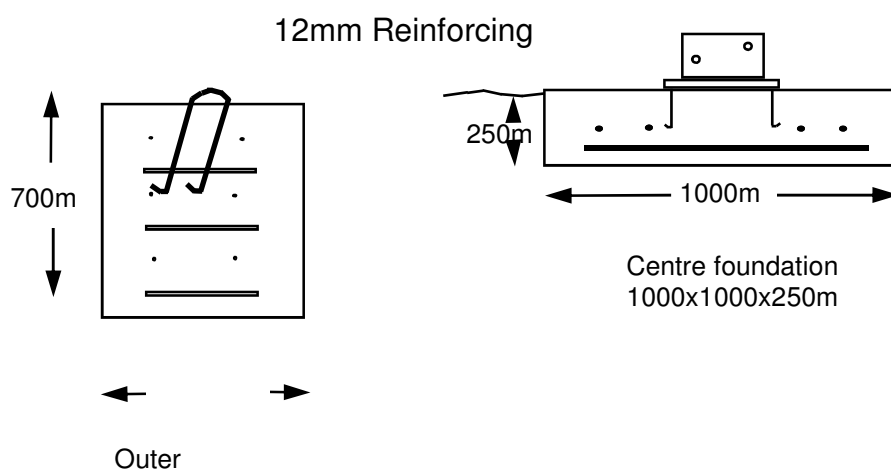

19.5 METRE TOWER - PIPE DRILLING DETAIL (dim. in mm) NOT TO SCALE

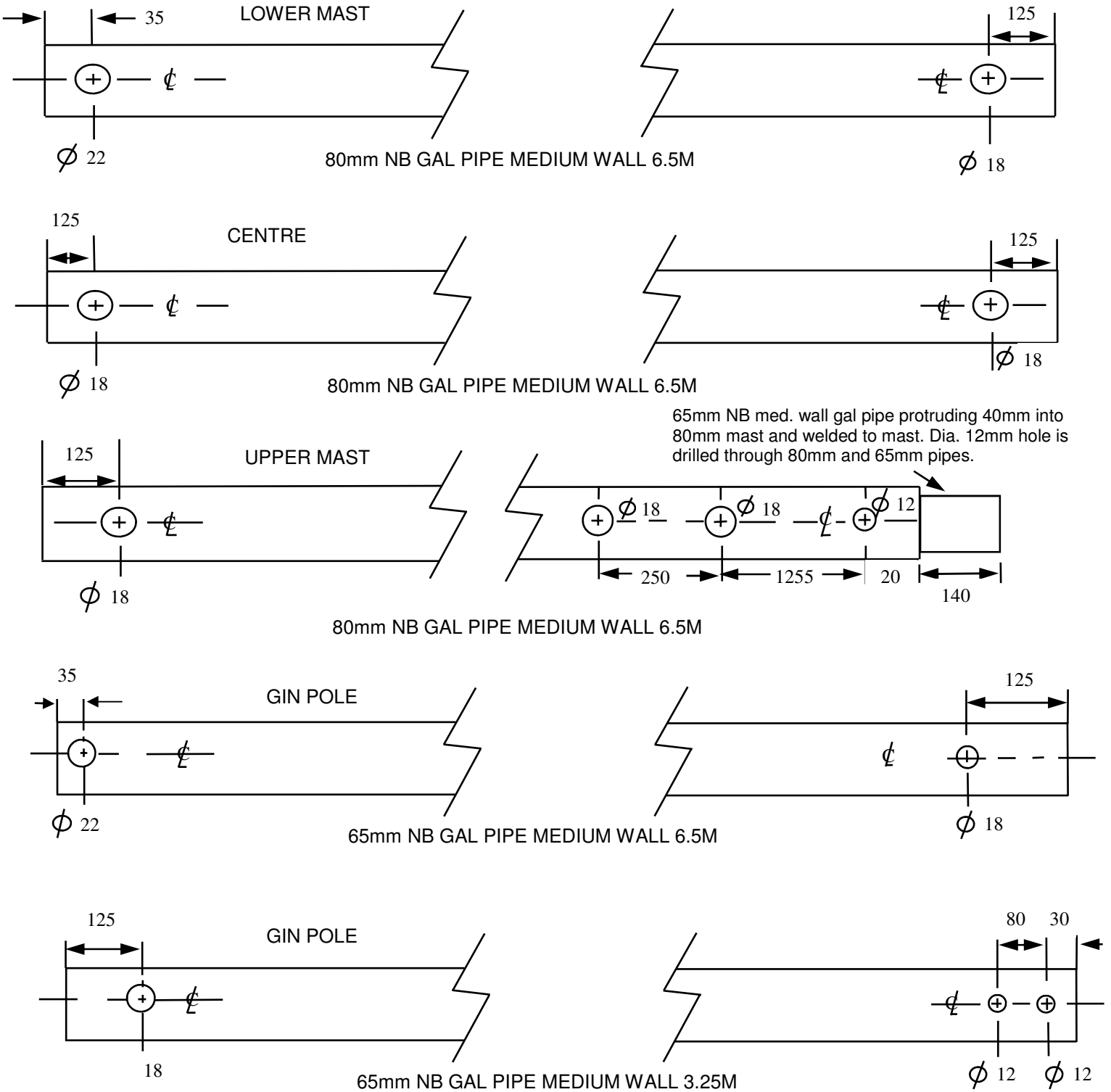

NOTE: ALL HOLES THROUGH BOTH SIDES OF PIPE

Fig 5.